

## Arizona's Salt River Project Uses Magnum 6K25 Fiber Switches to Manage New Electric Power Utility Substations

### An Industrial Ethernet Application

#### TECHNOLOGY TODAY

Events of the last few years have demonstrated the power industry's need to provide plentiful, reliable electric power under increasingly demanding conditions. Power utilities are increasingly turning to networking solutions using Industrial Ethernet equipment because of its high reliability and emphasis on standards, which translates into lower costs and more flexibility than earlier proprietary networking strategies.

Modular versions of Ethernet switches that provide a mix of noise-immune fiber and convenient copper ports as well as 10 Mb and 100 Mb speeds allow Ethernet LANs to be designed into substations where control and instrumentation equipment and connection techniques are evolving and changing rapidly. Highly reliable Ethernet products make it possible to maintain high availability of electric power to the public.

#### ABOUT SALT RIVER PROJECT

The Salt River Project (SRP), based in Phoenix, was established in 1903 as the nation's first multipurpose reclamation project authorized under the National Reclamation Act, and is now the nation's third largest public power utility. Today, the Salt River Project Agricultural Improvement and Power District and its partners generate power from plants across the southwest with a diverse fuel mix of coal, nuclear, hydro, natural gas and oil. This allows SRP to take advantage of favorable markets providing its power at the lowest possible cost.

SRP is a member of the Western Electricity Coordinating Council (WECC), which is responsible for coordinating electricity system reliability in the west. SRP has a reputation as an industry leader in power reliability and customer satisfaction.

#### THE CHALLENGE

To meet the growing power needs of metropolitan Phoenix, SRP is adding generating facilities and transmission lines that will protect SRP customers from market fluctuations and power shortages. SRP is also upgrading its nearly 200 existing substations to feature Ethernet in the control system over a three-year rollout period. The application requires Ethernet switches for the control and communications workhorse of each substation to offer high reliability, a dual DC power supply for redundancy, and Ethernet media configuration flexibility that includes 10 Mb fiber ports. SRP is experiencing continued migration from copper to fiber, and gradual migration from 10 Mb to 100 Mb Ethernet speed.

Newer substations, such as the new 500 KV Rudd substation on the west side of Phoenix, show that a modern power substation requires even more LAN flexibility. These huge substations are handling high voltage lines that must be stepped down for neighborhoods with lower-level power requirements, and the equipment must be able to operate in a hostile environment. The communications demands on a power company such as SRP require advanced telco-level communications systems to interface between the "edge" networks in the substations and the SRP central office.

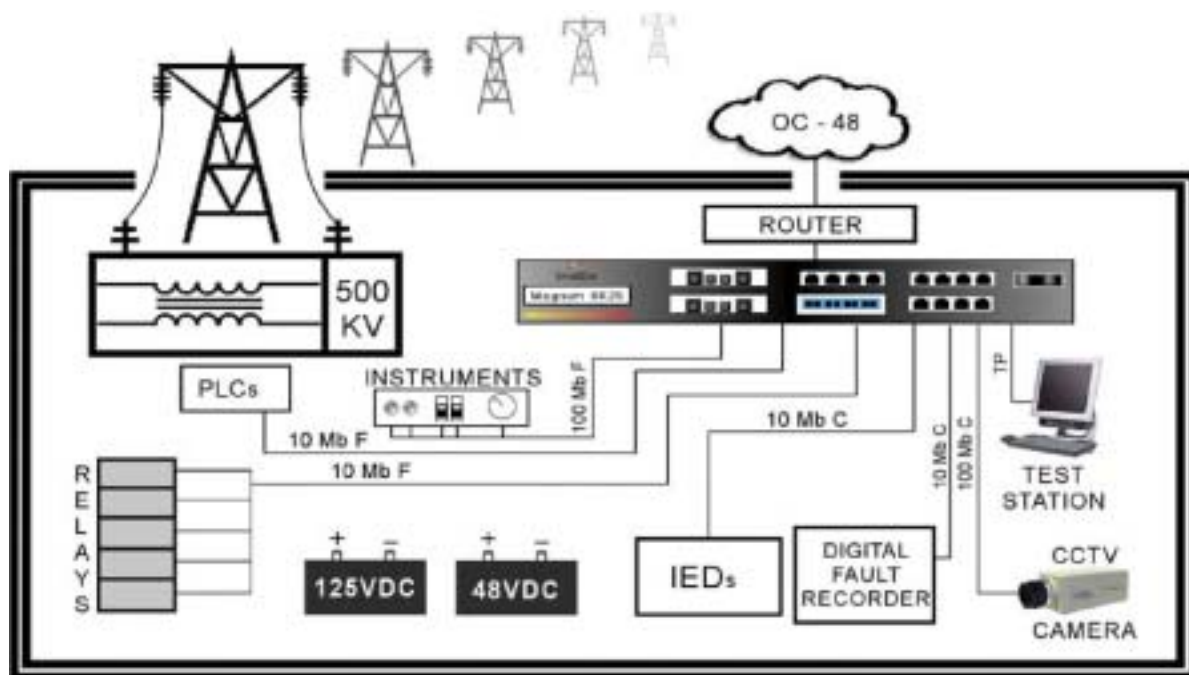

SRP, Rudd Substation, Phoenix, Arizona

## SRP, Power Utility Substations

### THE SOLUTION

SRP engineers chose GarrettCom's Magnum 6K25 Fiber Switches for the Ethernet LAN in the new Rudd substation. The Magnum product line offers high configuration flexibility, and high reliability as shown by the NEBS certifications which is appreciated by the telecommunications background of many of the SRP engineers. NEBS testing fulfills the criteria deemed necessary by the telecommunications industry to support mission-critical central office applications that demand high reliability, electromagnetic radiation immunity, and sustained operation under temperature stress among other tough conditions.

While older substations bundle serial inputs through a port switch for access to the Ethernet information highway, the new Rudd substation design has more direct sensor and control signal inputs to Ethernet switches. As utilities install equipment such as digital recorders and closed circuit TV which make remote site management more secure and less expensive, the demand for cost-effective fiber Ethernet ports and modular LAN upgradeability will continue to grow.

The Magnum 6K25 Fiber Switches that are being installed in the new Rudd substation provide the most flexible connectivity in the industry. With per-port configuration flexibility for RJ-45 and all fiber port varieties, and with multiple DC power options, the Magnum 6K25s meet SRP's needs for a Switch that can adapt to the changing demands of a substation under construction, as well as the modularity to support later upgrades. The Magnum 6K25 Switch comes with network management software, which SRP has chosen not to implement for security reasons.

### THE RESULT

The SRP system-wide retrofit, which has been underway for a few years, has allowed SRP to prove for itself the Magnum products' quality and reliability. In addition, the breadth of the Magnum product line has enabled SRP to select the products it needs for each application, and to benefit from the cost advantages of GarrettCom's broad-spectrum of Ethernet LAN products.

### MAGNUM 6K25 MANAGED FIBER SWITCH

The Magnum 6K25 Managed Fiber Switch supports up to 24 built-in fiber ports with optional 1Gb fiber uplink capability. Unlike other managed switches available with industrial specifications, the Magnum 6K25 offers per-port configurability for RJ-45 connectors and 10 Mb fiber as well as the full range of 100 Mb fiber and Gigabit connector types.

Industrial users can take advantage of fiber's inherent noise immunity and extended distance support without the need for expensive, space-consuming media converters. The Magnum 6K25 Managed Fiber Switch comes with Managed Networks Software (MNS-6K) that provides basic switch management, monitoring, and security. It is based on network standards and is easily integrated into existing networks.

Like all Magnum Plantwide LAN Ethernet products, the Magnum 6K25 Managed Switch features extended operating temperature range, rack-mounting for IT centers, conformal coating optional to protect circuitry from exposure to high humidity and dust, high reliability, and high availability with a choice of AC worldwide power, and DC power from 125 VDC, 24 VDC, or -48 VDC sources.

### ABOUT GARRETTCOM

GarrettCom, Inc., is the leading manufacturer of industrial and carrier-class Ethernet LAN products. GarrettCom offers a comprehensive line of ETSI and NEBS-certified switches and hubs for use in telecommunications, industrial, and automated factory environments. GarrettCom markets its products through a network of resellers, OEMs, system integrators, and distributors worldwide. For more information on GarrettCom and its products, visit [www.GarrettCom.com](http://www.GarrettCom.com).

©2003 GarrettCom, Inc. GarrettCom, Magnum, and Personal Switch are trademarks and Personal Hub is a registered trademark of GarrettCom, Inc. NEBS is a trademark of Telcordia Technologies. Ethernet is a trademark of Xerox Corporation. All other products and/or company names are trademarks of their respective owners.

